

MASTERPRO
PREMIUM QUALITY

THE ULTIMATE PIZZA OVEN

MPPIZZA0BK

master-pro.com.au

FEATURES AND PARTS

- Dual heating elements
- Removable ceramic baking stone
- Heats up to 400°C
- Two serving paddles
- Built in alarm timer
- 200-240V ~ 50-60Hz
- 1200W

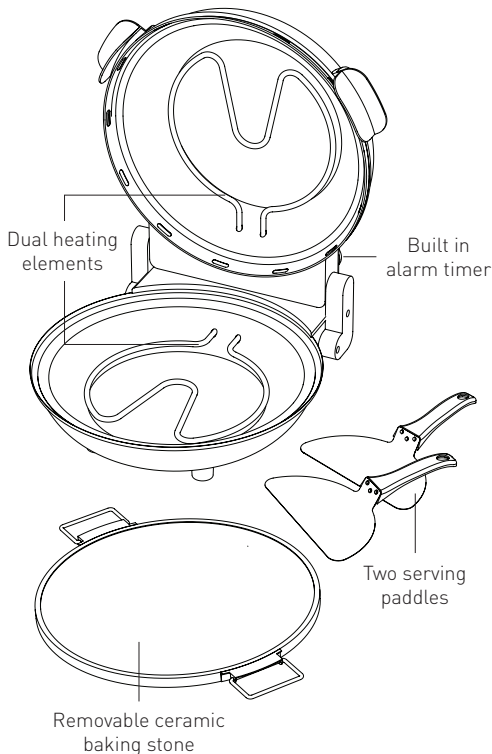

SAFETY FIRST

This appliance is not intended for use by persons (including children) with reduced physical, sensory or mental capabilities, or lack of experience and knowledge, unless they have been given supervision or instruction concerning use of the appliance by a person responsible for their safety.

Children should be supervised to ensure they do not play with the appliance.

- Read all the instructions before operating appliance and retain for future use.
- This appliance is intended for indoor household use only.
- The supply cord should be regularly examined for signs of damage, and if the cord is damaged, the appliance must not be used.
- If the supply cord is damaged, it must be replaced by qualified persons to avoid a hazard.
- Pull out from power outlet by grasping the plug – do not pull the cord.
- Do not use an extension cord. Do not immerse appliance, plug or cord in water or any other liquid.
- Do not allow cord to touch hot surfaces.
- This appliance is not to be operated by means of an external timer or separate remote-control system.
- Unplug appliance when not in use or when being cleaned.
- Turn heating dial to '0', unplug and allow to cool before storing.
- The appliance should always be used on a hard and stable surface, such as a table or bench top.
- Do not use appliance for anything other than its intended use.
- Do not use a damaged appliance.
- Warning: Avoid spillage on the connector.
- Caution: To prevent damage to the appliance do not use alkaline cleaning agents when cleaning, use a soft cloth and a mild detergent.
- Surfaces of appliance will become hot during use. Take care to only touch the handle and knob when appliance is hot. Wearing gloves is recommended to ensure safety. The heating element surface is subject to residual heat after use.
- Hot steam will be released quickly when opening appliance – exercise extreme caution when lifting open lid.
- Store these instructions for future reference.

PACKAGING AND RECYCLING

The materials used for this product's packaging can be reused, recycled and disposed of through specific waste streams. REUSE: Keep packaging to safely store or transport your appliance, preventing damage.

- RECYCLE: Look for recycling symbols on packaging components to identify if they are recyclable. Check with your local authority to find out what materials are accepted for recycling in your area.
- DISPOSE: Look for symbols on packaging components and dispose of materials accordingly.

OPERATING YOUR PIZZA OVEN

BEFORE FIRST USE

Run appliance for 10 minutes on heat setting '5'. This will burn away any lubricants from the heating elements and season the baking stone.

MAKING PIZZA

- Ensure the pizza oven is empty, aside from the ceramic baking stone.
- Turn heating dial to '0' and plug appliance into a power outlet.
- Turn heating dial to heat setting '5'. The heat indicator light will remain on for around 10 minutes until appliance has finished pre-heating.
- Once the heat indicator light turns off, use the paddles to transfer your pizza directly onto hot baking stone.
- Do not use sticky dough on the stone or paddles. If your pizza has a sticky base (if the dough is fresh), flour the stone and paddles before transferring the pizza.
- Warning: Only use handles to open the oven. Oven gloves are recommended. The oven will emit hot steam when opened.
- For best results, ensure that frozen pizzas and frozen pizza bases are thawed before placing in oven. Pita bread can also be used as a pizza base option. (Pita bread will only take 2-3 minutes to cook).
- Do not allow toppings to touch the top heating element as this will cause burning.
- Close appliance lid. Most pizzas will take 4-5 minutes to cook. It is recommended that you check the progress of your pizza after 3 minutes.
- If you find that the top of the pizza is cooking too quickly, turn the heat setting down. Alternatively, you can leave the lid open while the base finishes cooking.
- When cooking multiple pizzas, leave the lid open for a few minutes between cooking. Turn the heat setting down if bases cook too quickly.
- Once cooked, remove pizza using the paddles.

- For toasted sandwiches, pre-heat your oven at setting '5'. Prepare your sandwich with chosen fillings, place the sandwich on stone and close lid. Sandwich will toast in 3-4 minutes. Flip over and cook for a further minute or until desired. Once toasted, spread butter over the outside of sandwich.

CARE

- Allow the oven to cool before cleaning any parts. Clean the exterior of appliance with a damp cloth.
- The removable ceramic baking stone is made from a natural material and therefore will discolour over the course of time. Darkening in colour, staining and small scratches on the pizza stone are not a cause for concern.
- To clean baking stone, scrape off excess food with a spatula or bristled brush. Wipe clean with a paper towel or tea towel. Resistant residue adds to the seasoning of baking stone over time.
- Do not use cooking oil, water or any detergents on baking stone.
- Do not use knives or pizza cutters directly on baking stone.
- Clean paddles in warm water with mild detergent and dry thoroughly.

STORAGE

Once appliance has cooled and been cleaned, store in a dry place. Ensure no residual moisture is left over from cleaning.

OUR 12 MONTH GUARANTEE

In Australia, our goods come with guarantees that cannot be excluded under the Australian Consumer Law. You are entitled to a replacement or refund for a major failure and compensation for any other reasonably foreseeable loss or damage. You are also entitled to have the goods repaired if the goods fail to be of acceptable quality and the failure does not amount to a major failure.

We stand by this product. Therefore we offer a 12 month guarantee on the heating element. The benefits of this guarantee are in addition to any rights and remedies imposed by Australian Consumer Law. Our guarantee excludes normal wear and tear and instances where care and use instructions have not been followed.

What Albi will do: During this guarantee period Albi will repair, replace or refund any defective product. If identical product is not available for replacement, a similar product may be offered. Albi asks you to cover the cost of postage/transit if the product needs to be sent back to us for inspection. If Albi deems the product is defective, we will reimburse your postage/transit expenses. Albi will be responsible for the postage/transit of the repaired/replacement product back to you.

What to do: If a fault/defect is identified cease using the product immediately.

To make a claim on this guarantee, take the product, proof of purchase and full details of the alleged defect to the retailer from whom the product was purchased. If you cannot access the retailer or are unsatisfied with the solution offered by the retailer contact Albi via the details below.

CONTACT

Albi

87 Chifley Drive, Preston, Victoria 3072

P: +61 (03) 9474 1300

E: albi@albi.com.au

albi.com.au

RECIPES

Basic Pizza Dough

Ingredients:

- 1 x 7g sachet of dry yeast
- 1 cup warm water
- 1 tsp. sugar
- 450g plain flour
- 2 tbsp. olive oil
- ¼ tsp. salt

Method:

Whisk warm water, yeast and sugar in a jug until mixed. Cover and set aside in a warm place for 5 minutes, or until mixture bubbles.

Sift flour into a bowl, add salt, yeast mixture and oil and knead for 10 minutes or until elastic. Place in a greased bowl, cover and set aside for 30 minutes or until dough has doubled in size.

Use your fist to pound dough down. On a lightly floured surface, cut into 4 portions and knead before rolling out on to a base.

Margherita Pizza

Ingredients:

- Basic pizza dough
- Fresh basil
- 2 cloves garlic, crushed
- 2 tbsp. tomato paste
- 1 cup water
- 1 tbsp. olive oil
- 700ml passata
- Mozzarella

Method:

Sauté onion and garlic in olive oil until translucent. Add tomato paste, passata and water. Simmer for 30 minutes to reduce.

Preheat Ultimate Pizza Oven. Roll out dough and place onto lightly floured ceramic baking stone. Top base with homemade sauce. Roughly tear pieces of mozzarella and place over the top.

Close lid adjust heat setting to '2.5'. Check after 3 minutes and cook further if desired. Finish with fresh basil and enjoy.

Smoked Salmon Pizza

Ingredients:

- Basic pizza dough
- Horseradish cream
- Olives halved
- Cherry tomatoes
- Mozzarella
- Fresh basil
- Smoked salmon

Method:

Preheat Ultimate Pizza Oven. Roll out dough and place onto lightly floured ceramic baking stone. Spread with horseradish cream and cover with mozzarella.

Close lid and adjust heat setting to 2.5, cook for 2 minutes. Add smoked salmon, chopped olives and tomatoes. Cook for a further 3 minutes. Top pizza with basil and enjoy.

Toasted Sandwiches

Preheat Ultimate Pizza Oven.

Simply fill bread slices with desired filling and place onto ceramic baking stone.

Close lid and set temperature dial to 2.

Check after 2 minutes and flip over. Cook for a further minute or until done.

When cooked, spread butter onto outside of toasted sandwich and enjoy.