

amalfi

VEIGA ULTRASONIC DIFFUSER

150ML

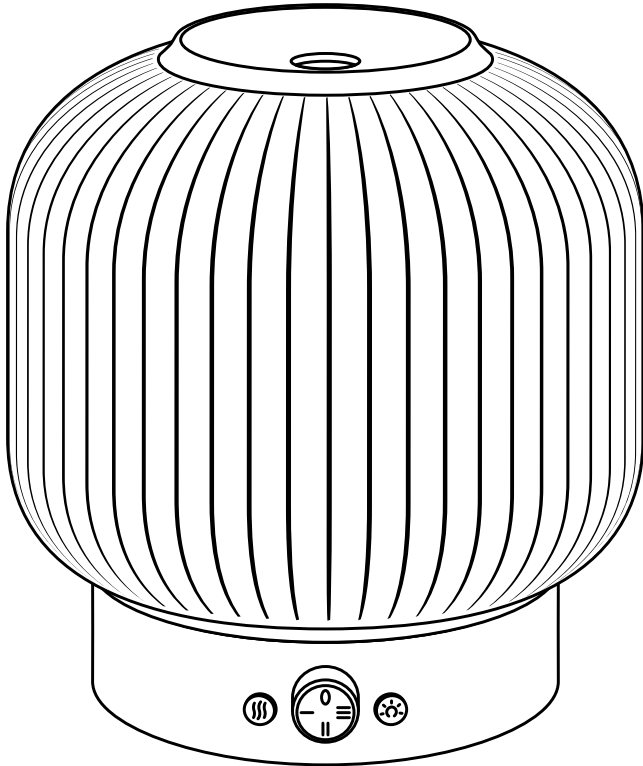

SAFETY INSTRUCTIONS:

The following safety instructions should always be followed, to reduce the risk of damage or injury

Retain these instructions for future reference. Read all the instructions carefully before using the product

This product must only be used as intended in accordance with the enclosed operating instructions.

1. The appliance is not to be used by persons (including children) with reduced physical, sensory or mental capabilities, or lack of experience and knowledge, unless they have been given supervision or instruction concerning the use of the appliance by a person responsible for their safety. Children being supervised not to play with the appliance.
2. The appliance must only be supplied at SELV (safety extra low voltage) and must be used with the adaptor power supply provided.
3. Do not carry the diffuser by the mains cable or pull the cable to remove the plug from the socket.
4. If the diffuser stops unexpectedly or appears to malfunction, switch off the power supply
5. Do not operate the diffuser with damaged cord or plug or after the diffuser malfunctions or has been damaged in any manner. If the diffuser is damaged or broken, do not repair yourself, if the power cord or the plug is broken or damaged, do not repair or change yourself, please send the diffuser to qualified service centre for repair or service.
6. Switch off the power supply when not in use. Unplug the appliance during filling or cleaning.
7. Avoid positioning the diffuser where the power cable might be damaged
8. Keep the diffuser and cable away from sources of heat or anything that may cause damage
9. Ensure the diffuser is switched OFF before connecting the mains power supply.
10. Be aware that some surfaces may become hot. Do not touch hot surfaces
11. This product has not been designed to be used by children.
12. Children should always be closely supervised, at all times, when they are near any electrical appliance
13. To protect against electric shock, never allow the diffuser, the mains cable or plug to come into contact with water or any other liquid
14. If the diffuser becomes wet outside of the reservoir DO NOT plug it in until its completely dry
15. Always ensure that hands are dry before operating or adjusting any switch on the diffuser or touching the plug and mains supply connections.
16. To disconnect, first ensure that all controls are in the OFF position
17. Keep all ventilation slots, filters, etc. uncovered and clear of debris. Never drop or insert objects into the openings.
18. Do not use outdoors. This appliance has been designed for domestic indoor use only.

PRODUCT DESCRIPTION

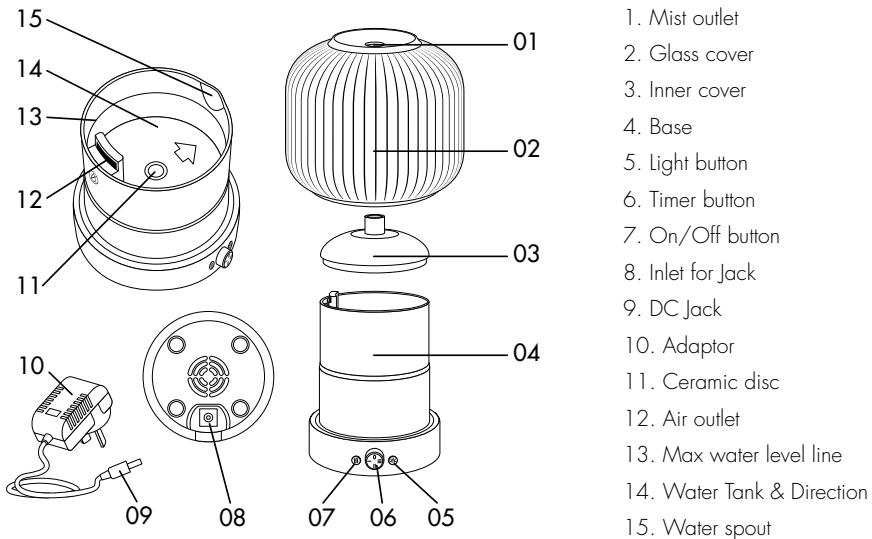

INSTRUCTIONS

A detailed diagram can be found below.

1. Place the diffuser on a flat, stable surface, away from the edge.
2. Carefully remove the glass outer cover.
3. Remove the inner cover
4. Fill the reservoir with **distilled water** (bottled water or tap water); do not exceed the maximum water level – 150 ml (Indicated by the word MAX in red letters).
5. Then add a few drops of **essential oil** (5-7 drops) to the water tank.
6. Replace the inner cover & the glass outer cover on the diffuser.
7. Plug the connecting cable into the DC-jack located on the rear of the diffuser.
8. Plug the adaptor into the power supply & push on the On/Off Button – Turn the rotating button if you wish to use select the timer function – if not leave timer button on "0".

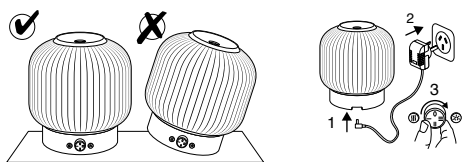

MAINTENANCE

It is recommended to change the water in the reservoir frequently and to clean the diffuser regularly, especially if you wish to change the aroma.

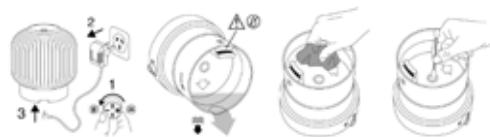

1. Turn off and unplug the device.
2. Carefully Remove the glass cover & inner cover and empty the water from the reservoir. **Empty the water using the water spout, on the opposite side of the**

air outlet. Do not empty the water in the air outlet, this would damage the diffuser.

3. Clean the interior of the diffuser with a soft tissue and a little water. If necessary, use some heavily diluted vinegar. Do not use corrosive detergents. Gently wipe the ceramic disc with a cotton bud, being careful not to scratch it.

IMPORTANT: DO NOT press heavily or scratch the ultrasonic mechanism in the water tank during cleaning.

FUNCTIONS

Left button – On/Off Button

- Press 1: Continuous diffusion
- Press 2: 30sec on/off intermittent diffusion
- Press 3: Off

Middle Turning knob – Timer Button

- Turn on 1st position: Timer 1 hour, than diffusion & light off
- Turn on 2nd position: Timer 2 hours, than diffusion & light off
- Turn on 3rd position: Timer 3 hours, than diffusion & light off
- At <0> position, continuous diffusion and light on, no timer function

Right button – Light Button

- Press 1: 100 % warm white
- Press 2: 50 % warm white light
- Press 3: Breathing light - 1 minute cycle (light begins to cycle between bright and dim according to designed breathing light cycle)
- Press 4: Lights Off

When the water level in the reservoir is insufficient or empty, the diffuser will stop automatically. When this happens, fill the reservoir with water following the instructions to return to normal function.

Precaution

1. Do not use as medical respirator.
2. Do not use the product when there is an abnormal noise, or the diffuser is overheating abnormally
3. Do not cover or block the mist outlet or air inlet
4. Use only 100% pure essential oils, DO NOT use inferior essential oils
5. Do not take off the cover while the diffuser is in operation
6. Do not place on an electronic device
7. Do not use hot water or mineral water, always use tap water or distilled water
8. Keep out of reach of children or pets

TROUBLESHOOTING

Please refer to below info when the unit falls to work properly

Fail to turn on the unit	<p>Is there enough water in the water tank?</p> <ul style="list-style-type: none"> - Add water in the water tank. <p>Does water amount exceed the Max line?</p> <ul style="list-style-type: none"> - Reduce the water amount and make sure it is below the MAX line <p>The diffuser was just unpacked and is very cold?</p> <ul style="list-style-type: none"> - Please wait unit reaches room temperature
Shut off suddenly during working	<p>Does water amount exceed the Max line?</p> <ul style="list-style-type: none"> -Reduce the water amount and make sure it is below the MAX line <p>Please check if the adaptor is well connected?</p> <ul style="list-style-type: none"> - Unplug the DC socket & plug it back in. Turn ON the unit.
No mist or abnormal mist	<p>Not enough water or too much water?</p> <ul style="list-style-type: none"> -Add water to the water tank but don't fill over the 150 ml MAX line. <p>Dirt on the Ultrasonic disc?</p> <ul style="list-style-type: none"> -Please refer to the maintenance instructions of unit & clean the unit. <p>Too much dirt on the air intake/mist outlet?</p> <ul style="list-style-type: none"> -Please use a small brush to clean the air intake part / mist outlet. <p>Different humidity environment and temperature will affect the mist density.</p>
Water leakage from the product	<p>Low temperature or high humidity?</p> <ul style="list-style-type: none"> -Under these conditions the mist may condense quickly into water droplets. <p>Please wipe droplets out.</p>

PRODUCT SPECIFICATIONS

Power input /output	AC:100-240V 50/60HZ / DC24V 0.5A
Electric consumption	12 W
Mist Mode	Continuous / Intermittent 30 sec on/ 30 sec off
Water capacity	150 ml

OUR 12 MONTH GUARANTEE

Our goods come with guarantees that cannot be excluded under the Australian Consumer Law. You are entitled to a replacement or refund for a major failure and compensation for any other reasonably foreseeable loss or damage. You are also entitled to have the goods repaired if the goods fail to be of acceptable quality and the failure does not amount to a major failure. We stand by this product. Therefore, we offer a 12 month guarantee on the motor. The benefits of this guarantee are in addition to any rights and remedies imposed by Australian Consumer Law. Our guarantee excludes normal wear and tear and instances where care and use instructions have not been followed.

What IsAlbi will do: During this guarantee period IsAlbi will repair, replace or refund any defective product. If identical product is not available for replacement, a similar product may be offered. IsAlbi asks you to cover the cost of postage/transit if the product needs to be sent back to us for inspection. If IsAlbi deems the product is defective, we will reimburse your postage/transit expenses. IsAlbi will be responsible for the postage/transit of the repaired/replacement product back to you. What to do: If a fault/defect is identified cease using the product immediately.

To make a claim on this guarantee, take the product, proof of purchase and full details of the alleged defect to the retailer from whom the product was purchased. If you cannot access the retailer or are unsatisfied with the solution offered by the retailer contact Albi via the details below.

IsAlbi

87 Chifley Drive, Preston, Victoria 3072

P: +61 (03) 9474 1300

E: enquiries@isalbi.com.au

isalbi.com.au